

Specifications

Performance

Rated Operating Capacity
Tipping Load
Hydraulic Pump Capacity
Travel Speed
Operating Weight

S70

700 lb. (318 kg)¹
1512 lb. (686kg)
9.8 gpm (37.8 L/min.)
6.1 mph (9.8 km/hr.)
2795 lb. (1268 kg)

Dimensions

Length (with bucket)
Width (with bucket)
Height
Height to Bucket Pin

97.3 in. (2472 mm)
36.0 in. (914 mm)
71.4 in. (1814 mm)
94.5 in. (2399 mm)

Engine

Model
Fuel/Cooling
Cylinders
SAE HP/Displacement
Fuel Tank Capacity

D1005-E
Diesel/Liquid
3
23.5/61.1 cu. in. (1.0 L)
6.5 gal. (24.6 L)

Operation

Steering and Drive
Hydraulics
Transmission

Forward, reverse, travel speed and steering controlled by two hand levers.
Raise/lower lift arms and dump/rollback bucket controlled by two foot pedals.
Hydrostatic, four-wheel drive.

Standard Features

5.70-12 Standard Tires	Lift Arm Support
Backup Alarm	Meters/Gauges/Warning Lights
Bob-Tach™	Operator Cab
Bobcat Interlock Control System (BICS™)	Parking Brake
Front & Rear Lights	Rear Window
Front Auxiliary Hydraulics	Seat Bar
High Back	Seat Belt
Cushion Seat	Spark Arresting System
Horn	

Options/Accessories

Attachment Control Kit	Skid-Steer Loader Training Kit
Bobcat Heavy-Duty Tires	Sound Cab (reduces noise)
Cab Enclosure	Special Applications Kit ³
Cab Heater	Strobe/Rotating Beacon Lights
Catalytic Purifier	Suspension Seat
Hydraulic Bucket Positioning ²	Top Window
Keyless Start Kit	Turf Tires
Service Safety Training Course	
Side Windows Kit	
Single-Point Lift Kit	

Bobcat S70... the loader for tough jobs in tight spots.

The compact Bobcat S70 skid-steer loader is small enough to get in the tight spots, yet tough enough to get you out.

This agile little workhorse is only 6 feet tall and 3 feet wide — the ideal size for scooting through narrow doorways, corridors, aisles, alleys and gates, and for working under low ceilings.

It's the perfect loader whenever the job is too big for a shovel or the space is too small for a larger machine — in backyards, barns, construction sites and demolition areas.

And versatile? You bet. With more than 20 Bobcat attachments to choose from, the S70 is a multi-attachment carrier that's ready to take on just about any job.

Plus — you get to do your work in the comfort and safety of the S70's operator-friendly, FOPS/ROPS-approved cab (Falling Object Protective Structure and Roll-Over Protective Structure). You'll also appreciate the comfortable high-back seat, low noise and easy entry and exit.

The S70 gives you 700 pounds of rated operating capacity and a rugged 23.5 horsepower liquid-cooled diesel engine that powers the hydrostatic 4-wheel drive.

Like all Bobcat loaders, the S70 allows quick, easy access to hydrostatic, hydraulic and engine systems, thanks to the swing-out tailgate and tip-up cab.

All this, and an excellent warranty, too. Check out the compact S70 skid-steer loader at your Bobcat dealer's showroom. It's the loader that's small in size, small in price, but big in value, comfort, performance and versatility!

700 LB.

Rated Operating Capacity

9.8 GPM

Hydraulic Flow

23.5 HP

Liquid-Cooled Diesel Engine

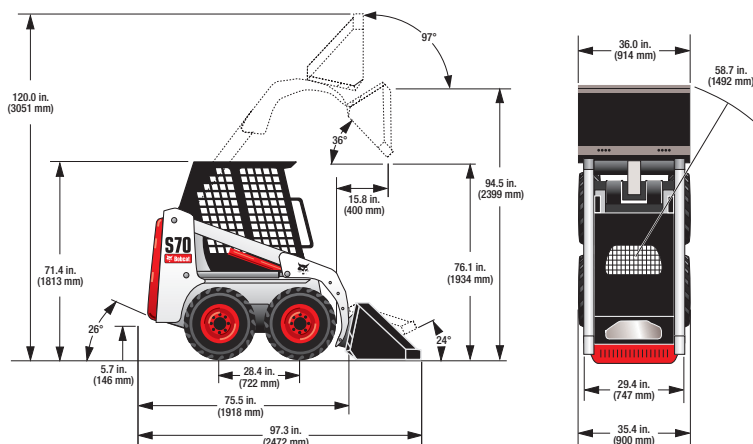

NOTE — Where applicable, dimensions are in accordance with Society of Automotive Engineers (SAE) and ISO standards. Specifications and design are subject to change without notice. Pictures of Bobcat loaders may show other than standard equipment. All dimensions are given for loader equipped with standard tires. All dimensions are shown in inches. Respective metric dimensions are enclosed by parentheses. Bobcat Company complies with the requirements of ISO 9001 as registered with BSI.

¹Operating capacity rated with standard digging bucket according to SAE standard J818. OPERATING CAPACITY TO EQUAL NO MORE THAN ONE HALF THE TIPPING LOAD.

²Bucket positioning helps operator keep the same tilt of the load during lifting.

³Includes polycarbonate front door, top and rear windows.

⁴Special application kit (see #3) must be used.

A - 5.70 x 12 Tires - 35.4 in. (900 mm)
23 x 8.50 - 12 Tires - 43.3 in. (1100 mm)

B - 5.70 x 12 Tires - 29.4 in. (747 mm)
23 x 8.50 - 12 Tires - 34.8 in. (884 mm)

C - 36 in. Bucket Width - 36.0 in. (914 mm)
44 in. Bucket Width - 44 in. (1118 mm)

Bobcat Company
P.O. Box 6000 • West Fargo, ND 58078
www.bobcat.com



Bobcat®

Bobcat Attachments for this model:

- Angle Broom
- Auger
- Backhoe
- Boring Unit
- Breaker⁴
- Bucket
- Combination Bucket
- Digger
- Dumping Hopper
- Grapple, Industrial
- Grapple, Root
- Grapple, Utility (for use with utility fork or bucket)
- Landplane
- Mini Scraper
- Pallet Fork
- Scraper
- Snowblower*
- Snow Blade
- Snow V-Blade*
- Soil Conditioner
- Stump Grinder
- Sweeper
- Tiller
- Tree Fork
- Trencher
- Utility Blade
- Utility Fork
- Utility Frame
- V-Blade
- Vibratory Plow

* Attachment Control Kit required.