



ES SERIES

ELECTRIC SCISSOR LIFTS

Performance

Platform Height—Elevated		
1930ES	18 ft 9 in.	5.72 m
2032ES	20 ft	6.10 m
2632ES	25 ft 6 in.	7.77 m
2646ES	26 ft	7.92 m
3246ES	31 ft 9 in.	9.68 m
Platform Capacity		
1930ES	500 lb	227 kg
2032ES	800 lb	363 kg
2632ES	500/800 lb ¹	227/363 kg
2646ES	1,000 lb	450 kg
3246ES	700 lb	318 kg
Capacity on Platform Extension		
	250 lb	113 kg
Lift/Lower Time		
1930ES	26/30 seconds	
2032ES	28/40 seconds	
2632ES	33/37 seconds	
2646ES	41/50 seconds	
3246ES	55/62 seconds	
Maximum Drive Height		
	Fully Elevated	
Weight*		
1930ES	2,710 lb	1,229 kg
2032ES	3,610 lb	1,638 kg
2632ES	4,635 lb	2,103 kg
2646ES/ 3246ES	4,975 lb	2,257 kg
Ground Bearing Pressure		
1930ES	109 psi	7.66 kg/cm ²
2032ES	81 psi	5.69 kg/cm ²
2632ES	90 psi	6.32 kg/cm ²
2646ES/ 3246ES	87 psi	6.11 kg/cm²
Drive Speed—Elevated		
	0.5 mph	0.8 km/h
Drive Speed—Lowered		
1930ES	3.0 mph	4.82 km/h
2032ES/ 2632ES	2.75 mph	4.43 km/h
2646ES/ 3246ES	2.50 mph	4.00 km/h
Gradeability		
	25%	
Turning Radius (Inside)		
	Zero	
Turning Radius (Outside)		
1930ES	69 in.	1.75 m
2032ES/ 2632ES	81 in.	2.06 m
2646ES/ 3246ES	95.1 in.	2.41 m

* Certain options or country standards will increase weight. 1. 800 lb restricted to 20 ft., 500 lb unrestricted. 2. 1,000 lb restricted to 26 ft., 700 lb unrestricted.

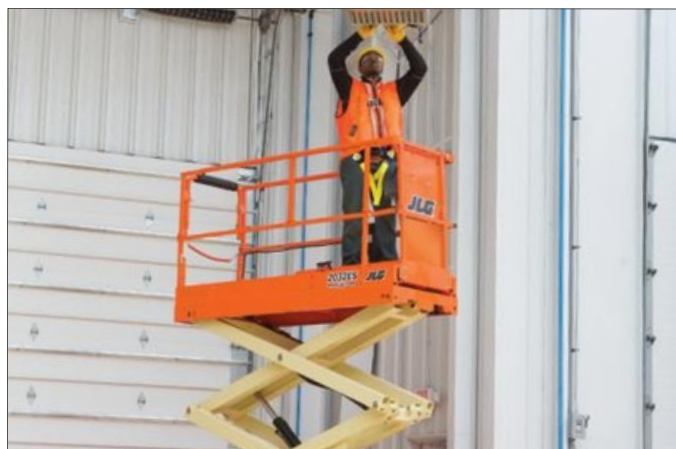

Tires

• Tire Size/Type	
1930ES	12.5 x 4 in. Non-Marking Solid
2032ES/2632ES/2646ES/3246ES	16 x 5 in. Non-Marking Solid

Brakes

- Electric/Friction

Standard Features

- Proportional Controls
- Industry Leading Duty Cycles
- Drywall Gate³
- Battery Condition Indicator
- Fold-Down Guard Rails⁴
- 110V-AC Receptacle in Platform
- Slide-Out Battery Trays
- Automatic Traction Control (ATC) All Motion Alarm
- 20 Amp Automatic SCR Charger
- Horn
- Hourmeter
- Manual Descent Pull Cable
- Tilt Alarm and Light
- Lanyard Attach Points
- Movable, Removable Platform Control
- Powder-Coated
- Console with Rail Mounting Bracket
- Nickel Plated Pins
- Lubrication Free Scissor Arm Bushings
- Scissor Maintenance Prop
- Mechanized Pothole Protection
- Machine Tie Downs
- Fork Lift Pockets
- 36 in. (91 cm) Roll-Out Deck
- Extension⁵ 50 in. (1.27 m) Roll-Out
- Deck Extension⁶
 - Four 6V, 220 Amp-Hour Deep Cycle Batteries

3. Not included on 1930ES. 4. Optional on 1930ES. 5. 1930ES, 2032ES and 2632ES. 6. 2646ES and 3246ES.

Standard Specifications

Power Source

Batteries	4x6V. 220 amp-hr	
Charger	20 Amp Automatic	
Drive	24V Electric	8hp

Hydraulic Reservoir

• Capacity		
1930ES/2032ES/2632ES	1.25 gal.	4.73 L
2646ES/3246ES	1.7 gal.	6.4 L
• Pump	Fixed Displacement	
	Gear	

Accessories & Options

- Spring-Loaded Gate
- Flashing Amber Beacon
- 245 Amp-Hour Batteries⁷
- 900W Inverter
- Lifting Lugs
- UL® EE Rating⁸
- Platform Padding
- Platform Padding with Proximity Switches
- 1/2 in. Airline
- Quik Welder Prep Package⁹
- Nite Bright¹⁰
- 220 Amp-Hour AGM Batteries¹¹
- Special Hydraulic Oils
- Accessory Packages:
 - Electrician's Package
 - Plumber's Package
 - JLG® Workstation
 - Panel Carrier Accessory⁷
 - Pipe Rack Accessory⁷
 - Quick Welder® Package
 - Plant Maintenance Package

7. Not available on the 1930ES. 8. Not available with AGM Batteries. 9. Includes power cable for welder and fire extinguisher. 10. Includes two platform mounted worklights. 11. Not available on EE rated units.

ES SERIES

ELECTRIC SCISSOR LIFTS

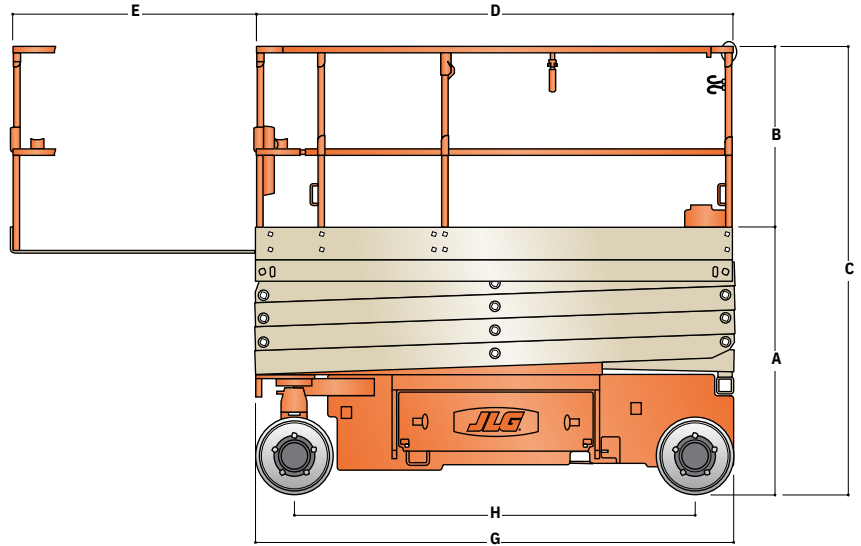
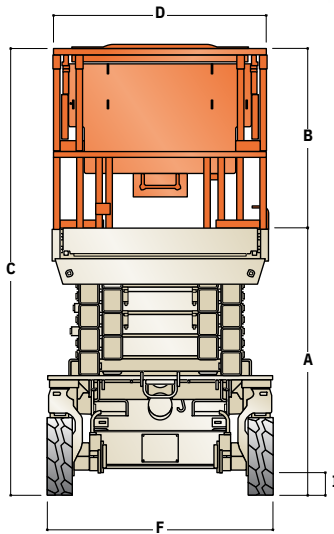

A. Platform Height—Lowered

1930ES	34 in.	0.86 m
2032ES	43.5 in.	1.10 m
2632ES	48.5 in.	1.23 m
2646ES	49.5 in.	1.26 m
3246ES	49.5 in.	1.26 m

B. Platform Railing Height

ES Series	43.3 in.	1.10 m
------------------	-----------------	---------------

C. Overall Height—Rails Lowered

1930ES	N/A	
2032ES	5 ft 11.5 in.	1.80 m
2632ES	6 ft 4.5 in.	1.94 m
2646ES/3246ES	6 ft 5.5 in.	1.97 m

D. Platform Size

1930ES	30 x 73.5 in.	0.76 x 1.87 m
2032ES/2632ES	30 x 90.5 in.	0.76 x 2.3 m
2646ES/3246ES	44 x 98.5 in.	1.12 x 2.5 m

E. Platform Extension

1930ES/2032ES/2632ES	35.5 in.	0.9 m
2646ES/3246ES	50 in.	1.27 m

F. Overall Width

1930ES	30 in.	76 cm
2032ES/2632ES	32 in.	81 cm
2646ES/3246ES	46 in.	1.17 m

G. Overall Length

1930ES	6 ft 1.5 in.	1.87 m
2032ES/2632ES	7 ft 6.5 in.	2.3 m
2646ES/3246ES	8 ft 2.5 in.	2.5 m

H. Wheelbase

1930ES	5 ft 3 in.	1.6 m
2032ES/2632ES	6 ft 2 in.	1.88 m
2646ES/3246ES	6 ft 10 in.	2.09 m

I. Ground Clearance

1930ES/2032ES/2632ES	3.5 in.	8.8 cm
2646ES/3246ES	5 in.	12.7 cm

SMART PEOPLE HIRE FROM...

